

PLAN

RUBBER SCRAPE HOLE

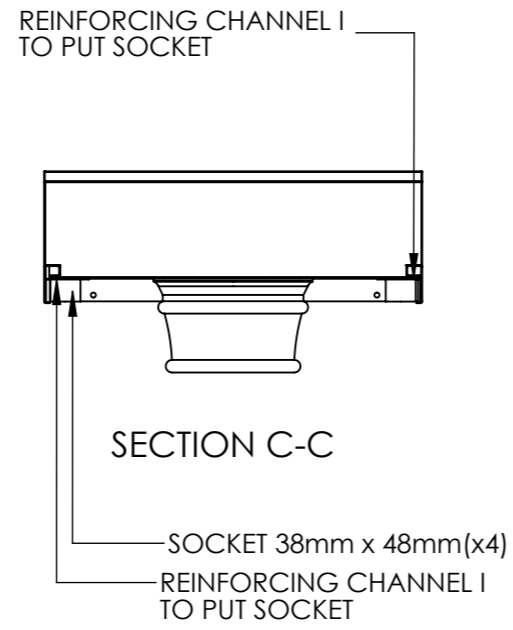

SECTION C-C

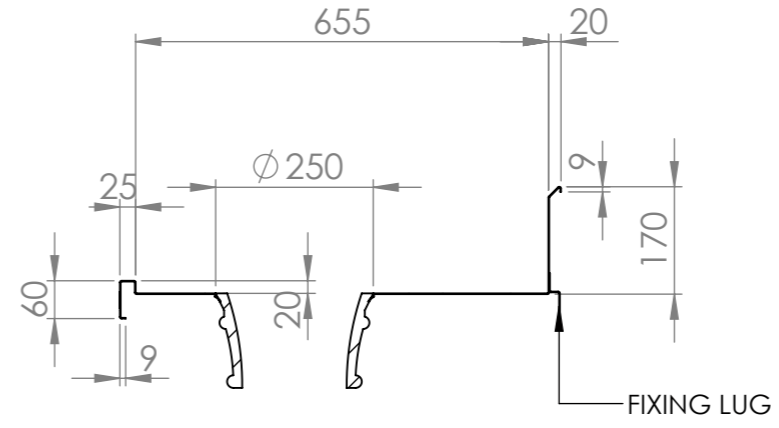

SECTION B-B



BIN NOT INCLUDED  
(ILLUSTRATION ONLY)

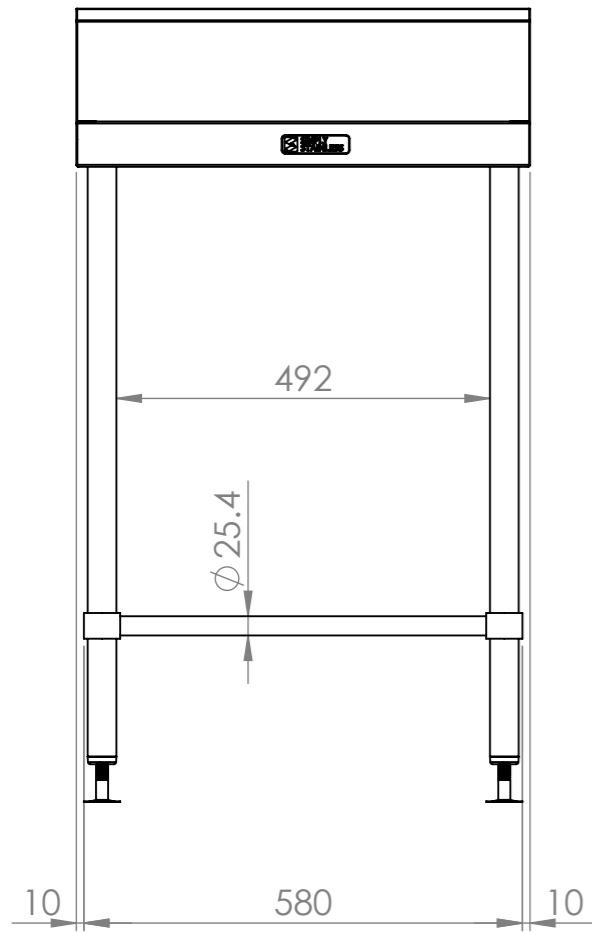

FRONT ELEVATION

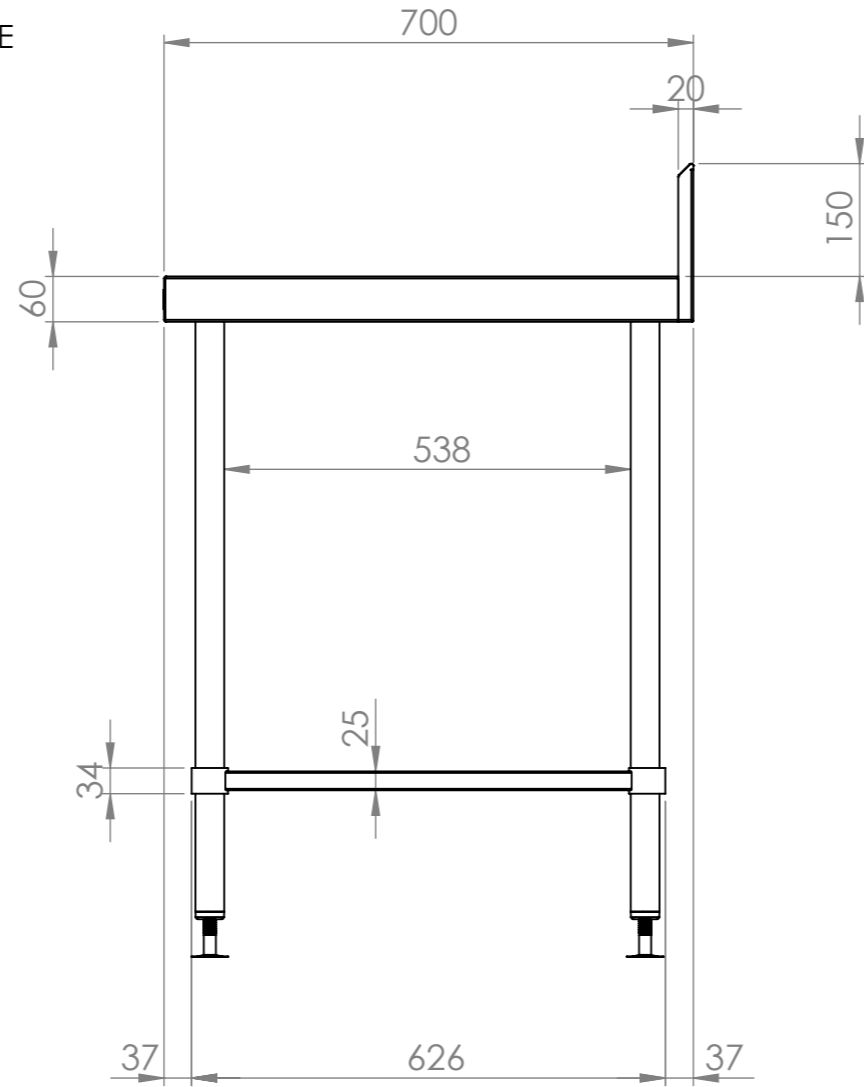

SIDE ELEVATION

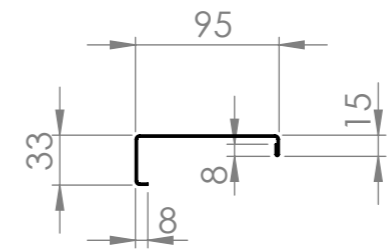

REINFORCING CHANNEL  
DETAIL

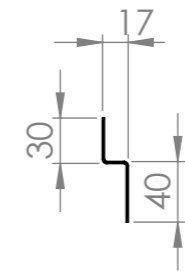

FIXING LUG  
DETAIL



Modular Sinks, Tables & Shelving  
COPYRIGHT © 2022

This drawing is the property of CI GROUP PTY LTD. Tradings as SIMPLY STAINLESS and It may not be copied, reproduced or modified in whole or in part without prior written permission of CI GROUP PTY LTD. SIMPLY STAINLESS reserves the right to change specification and design without notice.

**05-SH-7-0600**  
**BENCH WITH SCRAPE HOLE**

SIZE: A3

SCALE: 1:10

CONSTRUCTION NOTES :

1. TOPS MADE FROM 304 GRADE, 1.2mm STAINLESS STEEL.
2. CORE MADE FROM 3.0mm ZINC ANNEAL.
3. FRAME MADE FROM Ø38mm STAINLESS STEEL TUBE
4. LEG BRACE MADE FROM STAINLESS STEEL ROUND TUBE & SQUARE TUBE.
5. FEET ARE ADJUSTABLE STAINLESS STEEL DISC SHAPED FEET.